



features

- « Anodized heavy-duty aluminum frames.
 - « Heavy-duty acrylic lens.
 - « No sharp corners to snag lines or sails.
 - « Spare parts available.
 - « CE approval available. Please specify when ordering.
 - « Heavy-duty hinges.
 - « Quick acting, adjustable tie-down dogs.
 - « Molded trim ring, sewn screen available on select sizes.
 - « Locked vent position.
 - « SS riser arm rod.
- OPTIONS:
- « Inside/Outside opening.
 - « Powder coating.
 - « White acrylic lens.

LOW PROFILE EXTRUDED HATCHES

Bomar low profile hatches are the standard for the majority of quality boat builders throughout the world. The reason? These stylish, high-performance hatches combine sleek design with unsurpassed functionality. Constructed for rugged durability, they feature a heavy-duty aluminum frame and a high-impact acrylic lens. Design features include quick-acting tie-down dogs, trim ring and screen, lockable vent position, and the option of a shade screen and/or privacy shade on some models. Best of all, these low profile hatches are available in the largest selection of shapes and sizes of any hatch line on the market, from traditional deck hatches to larger fly bridge access doors. And you can specify these hatches in a variety of finishes, including anodized, powder coated, and polished aluminum.





Shown with optional high polished finish.



A&P Series ROUND HATCH SIZES

HATCH #	Height Deck to Lid		Hatch Opening		Cutout		OD Deck Flange		OD Lid	'A' Style	OD Lid 'P' Style	
	in	mm	in	mm	in	mm	in	mm	in	mm	in	mm
1115	1 ⁵ / ₁₆ "	24	10 ¹ / ₁₆ "	278	12 ¹ / ₁₆ "	306	13 ¹ / ₁₆ "	348	14 ³ / ₁₆ "	365	14 11/16	373
1139	1 ⁵ / ₁₆ "	24	19 ¹ / ₁₆ "	487	20 ⁵ / ₁₆ "	516	21 ¹ / ₁₆ "	557	22 ¹ / ₁₆ "	573	22 7/8	581
1149	1 ⁵ / ₁₆ "	24	24	610	25 ¹ / ₁₆ "	638	26 ³ / ₁₆ "	679	~	~	27 3/4	705
1170	1 ⁵ / ₁₆ "	24	15 ¹ / ₁₆ "	392	16 ¹ / ₁₆ "	421	18 ¹ / ₁₆ "	462	19 ¹ / ₁₆ "	484	19 1/8	486

Hatch Number	Height Deck To Lid		Hatch Opening			Cut Out		O.D. Deck Flange		O.D. Lid Style A		O.D. Lid Style C		O.D. Lid Style P	
	Z in mm	X in mm	Y in mm	X1 in mm	Y1 in mm	X2 in mm	Y2 in mm	X3 in mm	Y3 in mm	X4 in mm	Y4 in mm	X5 in mm	Y5 in mm		
1000	1 ⁵ / ₁₆ " (24)	9 ⁹ / ₁₆ " (244)	9 ⁹ / ₁₆ " (244)	10 ³ / ₁₆ " (273)	10 ³ / ₁₆ " (273)	12 ³ / ₁₆ " (314)	12 ³ / ₁₆ " (314)	13 ³ / ₁₆ " (335)	13 ³ / ₁₆ " (335)	13 ³ / ₁₆ " (340)	13 ³ / ₁₆ " (340)	13 ³ / ₁₆ " (341)	13 ³ / ₁₆ " (341)		
1002	1 ⁵ / ₁₆ " (24)	6 ⁷ / ₁₆ " (175)	6 ⁷ / ₁₆ " (175)	8" (203)	8" (203)	9 ⁹ / ₁₆ " (244)	9 ⁹ / ₁₆ " (244)	10 ¹ / ₁₆ " (265)	10 ¹ / ₁₆ " (265)	-	-	-	-		
1003	1 ⁵ / ₁₆ " (24)	8 ¹ / ₁₆ " (244)	8 ¹ / ₁₆ " (244)	9 ¹ / ₁₆ " (252)	9 ¹ / ₁₆ " (252)	11 ¹ / ₁₆ " (294)	11 ¹ / ₁₆ " (294)	12 ¹ / ₁₆ " (314)	12 ¹ / ₁₆ " (314)	-	-	12 ¹ / ₁₆ " (314)	12 ¹ / ₁₆ " (314)		
1005	1 ⁵ / ₁₆ " (24)	9 ¹ / ₁₆ " (232)	9 ¹ / ₁₆ " (232)	10 ¹ / ₁₆ " (260)	10 ¹ / ₁₆ " (260)	11 ¹ / ₁₆ " (302)	11 ¹ / ₁₆ " (302)	12 ¹ / ₁₆ " (325)	12 ¹ / ₁₆ " (325)	-	-	12 ¹ / ₁₆ " (329)	12 ¹ / ₁₆ " (329)		
1006	1 ⁵ / ₁₆ " (24)	8 ¹ / ₁₆ " (205)	6" (152)	9 ¹ / ₁₆ " (233)	7 ¹ / ₁₆ " (161)	10 ¹ / ₁₆ " (275)	8 ¹ / ₁₆ " (222)	-	-	-	-	11 ¹ / ₁₆ " (296)	9 ¹ / ₁₆ " (249)		
1008	1 ⁵ / ₁₆ " (24)	15 ¹ / ₁₆ " (392)	5 ¹ / ₁₆ " (148)	16 ¹ / ₁₆ " (421)	6 ¹ / ₁₆ " (176)	18 ¹ / ₁₆ " (462)	8 ¹ / ₁₆ " (217)	-	-	-	-	19 ¹ / ₁₆ " (489)	9 ¹ / ₁₆ " (244)		
1011	1 ⁵ / ₁₆ " (24)	13 ³ / ₁₆ " (337)	8" (203)	14 ³ / ₁₆ " (365)	9 ⁹ / ₁₆ " (232)	16" (406)	10 ³ / ₁₆ " (273)	16 ¹ / ₁₆ " (427)	11 ¹ / ₁₆ " (294)	17 ¹ / ₁₆ " (433)	11 ¹ / ₁₆ " (298)	17 ¹ / ₁₆ " (433)	11 ¹ / ₁₆ " (300)		
1015	1 ⁵ / ₁₆ " (24)	10 ⁷ / ₁₆ " (276)	10 ⁷ / ₁₆ " (276)	12" (305)	12" (305)	13 ³ / ₁₆ " (346)	13 ³ / ₁₆ " (346)	14 ¹ / ₁₆ " (367)	14 ¹ / ₁₆ " (367)	14 ¹ / ₁₆ " (371)	14 ¹ / ₁₆ " (371)	14 ¹ / ₁₆ " (373)	14 ¹ / ₁₆ " (373)		
1017	1 ⁵ / ₁₆ " (24)	21 ¹ / ₁₆ " (537)	22 ¹ / ₁₆ " (560)	22 ¹ / ₁₆ " (565)	23 ³ / ₁₆ " (589)	23 ³ / ₁₆ " (606)	24 ¹ / ₁₆ " (630)	-	-	-	-	24 ¹ / ₁₆ " (624)	25 ¹ / ₁₆ " (659)		
1019	1 ⁵ / ₁₆ " (24)	18 ¹ / ₁₆ " (478)	14 ¹ / ₁₆ " (364)	19 ¹ / ₁₆ " (506)	15 ¹ / ₁₆ " (392)	21 ¹ / ₁₆ " (548)	17 ¹ / ₁₆ " (433)	-	-	22 ³ / ₁₆ " (575)	18 ¹ / ₁₆ " (461)	22 ³ / ₁₆ " (578)	18 ¹ / ₁₆ " (464)		
1022	1 ⁵ / ₁₆ " (24)	21" (533)	21" (533)	22 ¹ / ₁₆ " (562)	22 ¹ / ₁₆ " (562)	23 ³ / ₁₆ " (603)	23 ³ / ₁₆ " (603)	24 ¹ / ₁₆ " (624)	24 ¹ / ₁₆ " (624)	-	-	-	-		
1023	1 ⁵ / ₁₆ " (24)	22 ¹ / ₁₆ " (560)	17 ¹ / ₁₆ " (437)	23 ³ / ₁₆ " (589)	18 ¹ / ₁₆ " (465)	24 ¹ / ₁₆ " (630)	19 ¹ / ₁₆ " (506)	25 ¹ / ₁₆ " (651)	20 ³ / ₁₆ " (527)	25 ¹ / ₁₆ " (652)	20 ³ / ₁₆ " (529)	-	-		
1027	1 ⁵ / ₁₆ " (24)	17 ¹ / ₁₆ " (433)	12 ¹ / ₁₆ " (306)	16 ¹ / ₁₆ " (462)	13 ³ / ₁₆ " (335)	19 ¹ / ₁₆ " (503)	14 ¹ / ₁₆ " (503)	20 ³ / ₁₆ " (524)	15 ¹ / ₁₆ " (397)	20 ³ / ₁₆ " (530)	15 ¹ / ₁₆ " (403)	-	-		
1028	1 ⁵ / ₁₆ " (24)	16 ¹ / ₁₆ " (424)	11 ¹ / ₁₆ " (294)	17 ¹ / ₁₆ " (452)	12 ¹ / ₁₆ " (322)	19 ¹ / ₁₆ " (494)	14 ¹ / ₁₆ " (364)	-	-	-	-	20 ¹ / ₁₆ " (521)	15 ¹ / ₁₆ " (391)		
1029	1 ⁵ / ₁₆ " (24)	17 ¹ / ₁₆ " (441)	12 ¹ / ₁₆ " (311)	18 ¹ / ₁₆ " (470)	13 ³ / ₁₆ " (340)	20 ¹ / ₁₆ " (511)	15" (381)	20 ¹ / ₁₆ " (532)	15 ¹ / ₁₆ " (402)	21 ¹ / ₁₆ " (538)	16 ¹ / ₁₆ " (408)	21 ¹ / ₁₆ " (538)	16 ¹ / ₁₆ " (408)		
1039	1 ⁵ / ₁₆ " (24)	19 ¹ / ₁₆ " (484)	19 ¹ / ₁₆ " (484)	20 ¹ / ₁₆ " (513)	20 ¹ / ₁₆ " (513)	21 ¹ / ₁₆ " (554)	21 ¹ / ₁₆ " (554)	22 ¹ / ₁₆ " (575)	22 ¹ / ₁₆ " (575)	22 ¹ / ₁₆ " (581)	22 ¹ / ₁₆ " (581)	22 ¹ / ₁₆ " (581)	22 ¹ / ₁₆ " (581)		
1040	1 ⁵ / ₁₆ " (24)	19 ¹ / ₁₆ " (491)	14 ¹ / ₁₆ " (362)	20 ¹ / ₁₆ " (519)	15 ¹ / ₁₆ " (391)	22 ¹ / ₁₆ " (560)	17" (432)	22 ¹ / ₁₆ " (581)	17 ¹ / ₁₆ " (452)	22 ¹ / ₁₆ " (583)	17 ¹ / ₁₆ " (454)	23 ¹ / ₁₆ " (587)	18 ¹ / ₁₆ " (459)		
1047	1 ⁵ / ₁₆ " (24)	27 ¹ / ₁₆ " (695)	26 ¹ / ₁₆ " (665)	26 ¹ / ₁₆ " (724)	27 ¹ / ₁₆ " (694)	30 ¹ / ₁₆ " (765)	29" (735)	-	-	31" (787)	30" (762)	-	-		
1048	1 ⁵ / ₁₆ " (24)	23 ¹ / ₁₆ " (597)	23 ¹ / ₁₆ " (597)	24 ¹ / ₁₆ " (625)	24 ¹ / ₁₆ " (625)	26 ¹ / ₁₆ " (667)	26 ¹ / ₁₆ " (667)	-	-	27 ¹ / ₁₆ " (694)	27 ¹ / ₁₆ " (694)	27 ¹ / ₁₆ " (694)	27 ¹ / ₁₆ " (694)		
1049	1 ⁵ / ₁₆ " (24)	24" (610)	24" (610)	25 ¹ / ₁₆ " (638)	25 ¹ / ₁₆ " (638)	26 ¹ / ₁₆ " (679)	26 ¹ / ₁₆ " (679)	27 ¹ / ₁₆ " (702)	27 ¹ / ₁₆ " (702)	27 ¹ / ₁₆ " (706)	27 ¹ / ₁₆ " (706)	27 ¹ / ₁₆ " (706)	27 ¹ / ₁₆ " (706)		

LOW PROFILE A&P SERIES SIZES

- « Cut Out Radius is 1 11/16" (43 mm) on all square and rectangular hatches.
- « CE approval available. Please specify when ordering.

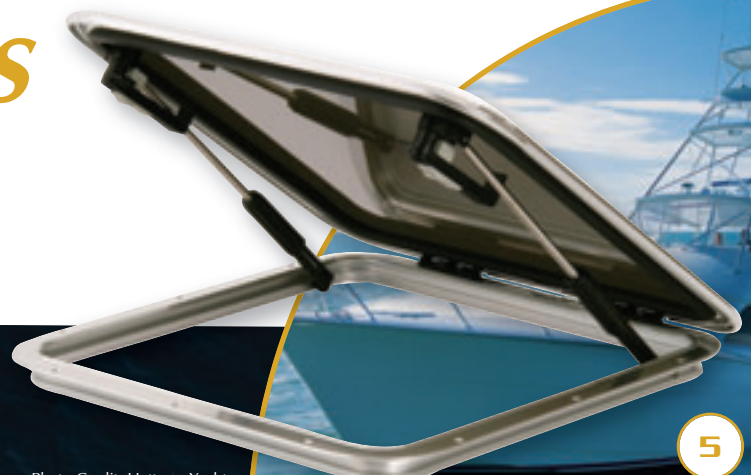

CUSTOM Hatchches

Low Profile &

LOW PROFILE A&P SERIES SIZES continued

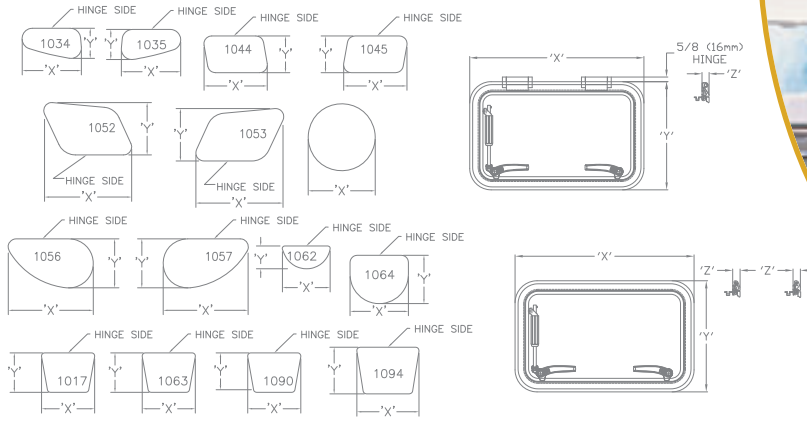

Hatch Number	Height Deck To Lid	Hatch Opening		Cut Out		O.D. Deck Flange		O.D. Lid Style A		O.D. Lid Style C		O.D. Lid Style P	
	Z in mm	X in mm	Y in mm	X1 in mm	Y1 in mm	X2 in mm	Y2 in mm	X3 in mm	Y3 in mm	X4 in mm	Y4 in mm	X4 in mm	Y4 in mm
1060	1 5/8" (24)	13" (300)	13" (300)	14 1/8" (359)	14 1/8" (359)	15 3/4" (400)	15 3/4" (400)	16 5/8" (421)	16 5/8" (421)	-	-	16 3/8" (427)	16 3/8" (427)
1061	1 5/8" (24)	43 1/8" (1110)	16 1/8" (424)	44 3/8" (1138)	17 3/8" (452)	46 1/8" (1180)	19 1/8" (494)	-	-	47 3/8" (1207)	20 1/2" (521)	-	-
1062	1 5/8" (24)	19 3/8" (487)	8 5/8" (227)	20 5/8" (516)	1 1/8" (256)	21 3/8" (557)	11 1/8" (297)	-	-	22 3/8" (578)	12 1/8" (327)	-	-
1063	1 5/8" (24)	35 5/8" (906)	19 1/8" (505)	36 3/8" (934)	21" (533)	33 3/8" (976)	22 3/8" (575)	-	-	38 3/8" (990)	23 3/8" (594)	-	-
1064	1 5/8" (24)	19 3/4" (502)	15 3/4" (400)	20 3/4" (630)	16 3/8" (429)	22 1/2" (572)	18 1/8" (470)	23 3/4" (591)	19 1/4" (490)	-	-	-	-
1065	1 5/8" (24)	12 1/2" (308)	12 1/2" (308)	13 1/4" (337)	13 1/4" (337)	14 1/8" (378)	14 1/8" (378)	15 1/8" (398)	15 1/8" (398)	-	-	-	-
1070	1 5/8" (24)	15 1/8" (392)	15 1/8" (392)	16 1/8" (421)	16 1/8" (421)	18 1/8" (462)	18 1/8" (462)	19" (483)	19" (483)	19 1/8" (490)	19 1/8" (490)	19 1/4" (489)	19 1/4" (489)
1075	1 5/8" (24)	15 1/8" (403)	15 1/8" (403)	17" (432)	17" (432)	18 5/8" (473)	18 5/8" (473)	19 1/2" (495)	19 1/2" (495)	-	-	19 1/8" (500)	19 1/8" (500)
1080	1 5/8" (24)	17 3/8" (441)	17 3/8" (441)	18 1/2" (470)	18 1/2" (470)	20 3/8" (511)	20 3/8" (511)	20 5/8" (532)	19 1/2" (506)	21 3/8" (538)	21 3/8" (538)	21 3/8" (538)	21 3/8" (538)
1086	1 5/8" (24)	18 1/8" (481)	18 1/8" (481)	20 1/8" (510)	20 1/8" (510)	21 1/8" (551)	21 1/8" (551)	-	-	22 1/8" (576)	22 1/8" (576)	22 3/8" (578)	22 3/8" (578)
1087	1 5/8" (24)	16 1/8" (413)	67 1/8" (1725)	17 3/8" (442)	69 1/8" (1753)	19" (483)	70 1/8" (1795)	-	-	31 3/8" (803)	71 3/8" (1822)	-	-
1090	1 5/8" (24)	20 1/8" (530)	15 1/2" (394)	22" (559)	16 5/8" (422)	23 3/8" (600)	19 1/8" (464)	24 5/8" (618)	19 1/8" (484)	24 1/2" (622)	19 1/4" (490)	24 1/2" (622)	19 1/4" (489)
1094	1 5/8" (24)	24 1/8" (616)	18 1/4" (460)	25 3/8" (645)	19 1/4" (489)	27" (686)	20 3/8" (530)	27 3/8" (702)	21 1/8" (551)	-	-	28 1/8" (713)	21 3/8" (557)
1096	1 5/8" (24)	24 3/8" (614)	50 3/8" (1275)	25 3/8" (643)	51 3/8" (1303)	26 1/8" (6843)	52 3/8" (1345)	-	-	28" (711)	54" (1372)	-	-

CUSTOM HATCH

From flybridge access, to hard top hatches, Bomar has the custom solutions to meet the needs and individual designs of all boat builders.

Custom Hatches are for OEM customers only.

